

HMF EXPRESS

(910) 452-1845 | Fax: (910) 452-1848 | www.HMFExpress.com

Problem Resolution Template for Door/Frame Field Fitting Issues

1.) General Notes:	
• Listen	• Take notes
• Ask questions	• Be committed to solving the issue
• Do not assign or accept fault/blame or responsibility until all facts are completely known	

2.) Key Components/Questions to Identify the Actual Problem	
• What seems to be the Issue?	
• Has the person you are talking to seen the opening or passing second hand info?	
• What measurements have been taken on the Frame (Fig. 1: Measure both rabbets)	
• What measurements have been taken on the Door? (Fig. 2: Measure both sides)	
• Is the Door/Frame in the correct opening? (Have Mark/Tag #'s been verified?)	
• Is the correct hardware being used? (Hvy. Wt. vs Std. Wt. hinges, etc.)	
Specific Frame Questions	Specific Door/Opening Questions
Is the frame square? Fig. 3	Will the door close? If not, why?
Is the frame level? Fig. 4	What gaps are between the door and the frame? Fig. 8
Is the frame twisted? Fig. 5	Is the door hitting the stop evenly top to bottom? Fig. 9
If welded, who welded the frame?	Does the door bind when closing? Yes/No
If KD, are the miters lining up? Fig. 6	Does the door swing without the closer arm on?
If KD, screws installed in gussets? Fig. 7	Are there any dents or damage to the door? Yes/No

3.) Solutions if Field Adjustments are Possible:	
• Grind/Drill Hinge "Pips": Fig. A	• Swag Hinges: Fig. C
• Shim Hinges: Fig. B	• Adjust Frame: (varies per condition)

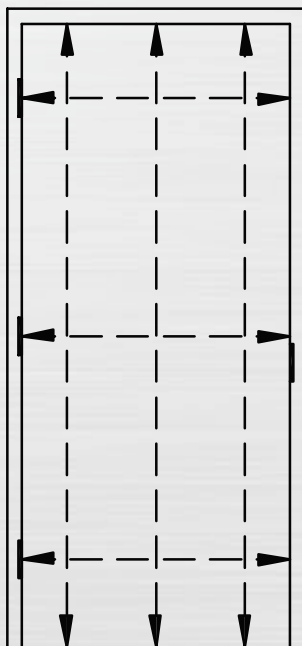

FIG. 1

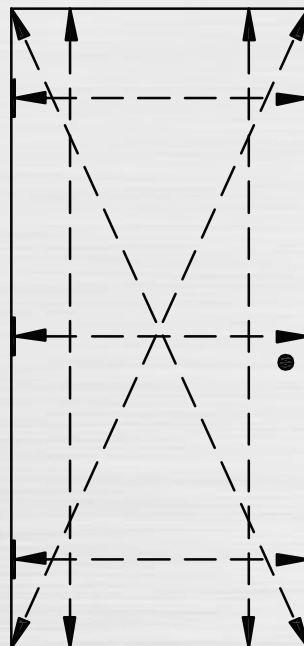

FIG. 2

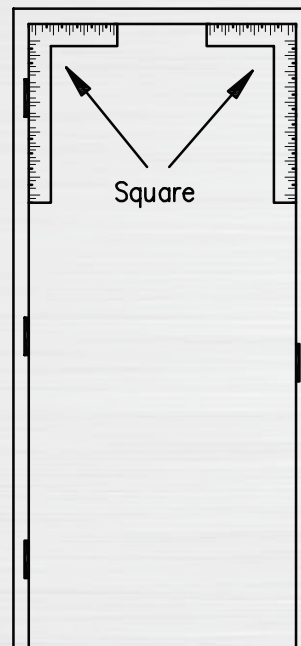

FIG. 3

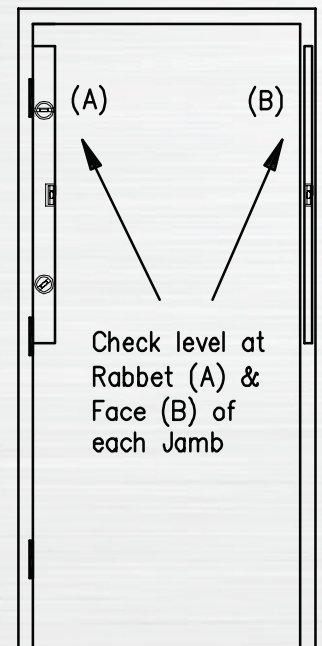
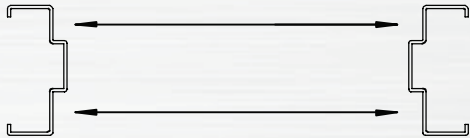

FIG. 4

HMF EXPRESS

(910) 452-1845 | Fax: (910) 452-1848 | www.HMFExpress.com

FIG. 5a



Compare measurements from each rabbet.
If they are different the frame is twisted.

FIG. 5b

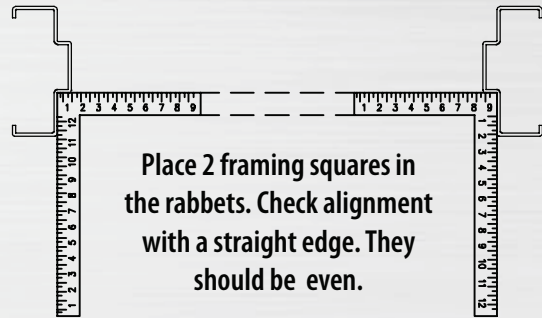

Place 2 framing squares in the rabbets. Check alignment with a straight edge. They should be even.

FIG. 6a

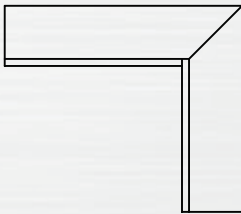

Proper alignment of miters shown.

FIG. 6b

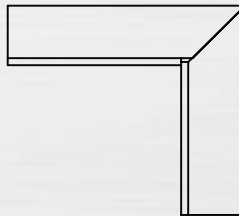

Compression anchor too tight?
Opening width too small?

FIG. 6c

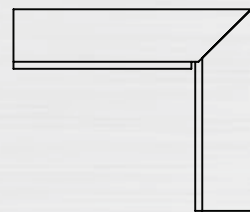

Screw installed in gusset prior to tightening of compression anchor?
Opening width too large?

FIG. 7

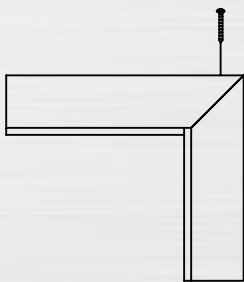

Recommended fastener is a #8 pan head SMS.

FIG. 8

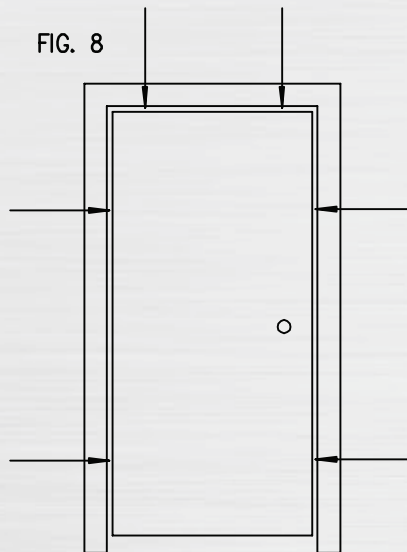

Clearances should be 1/8" at head and jamb with a tolerance of +1/16" or -1/32" for the opening size.

FIG. 9

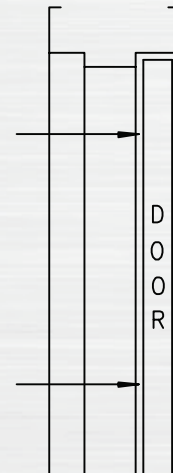

The door should rest against the silencers with no gaps at lock edge. Hinge edge of door should be consistent and not hitting the frame stop.

FIG. A

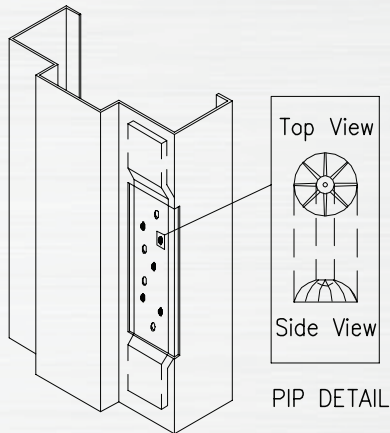

PIPS

- Pips are only present on frames with 4 1/2" standard weight hinges and are removed for heavy weight.
- To remove pips, grind off flush with small grinder or drill out with 3/16" bit (pip will "spin-off" while drilling).
- Remove pips farthest from stop to increase clearance at lock edge and closest to stop to decrease clearance at lock edge.
- Remove all pips to create 3/64" extra clearance.

FIG. B

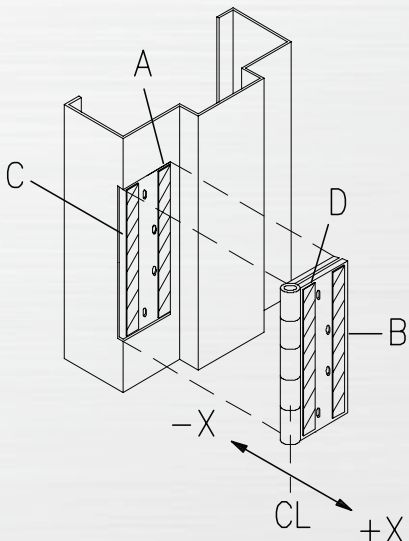

SHIMS

- Using shim (A) only will move both door and center line (CL) of hinge barrel in the -X direction.
- Using shim (B) only will move door only in the -X direction.
- Using shim (C) only will move both door and CL of hinge barrel in the +X direction.
- Using shim (d) only will move door only in the +X direction.
- Using both shims (C) & (D) will move door in the +X direction by a greater amount than using them individually.

FIG. C

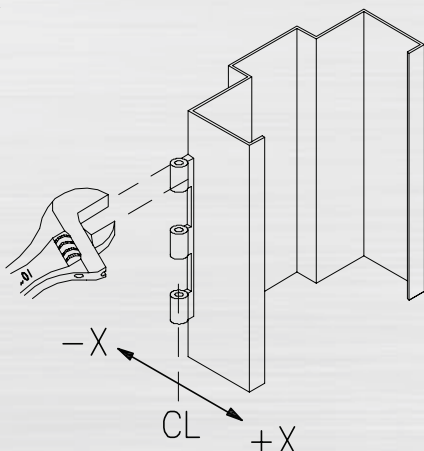

SWAGGING

***CAUTION: THIS ACTION COULD WEAKEN OR BREAK THE WELD AT THE HINGE REINFORCEMENT.**

- Remove hinge pins and using on 8" - 10" crescent wrench, bend all knuckles in +X directions to move door away from strike or -X direction to move door toward strike (tape jaws to protect hinge finish).
- Replace pins to check clearances and repeat procedure as necessary for required adjustment.
- Can be tried for mortise, weld-on, and non-ball bearing hinges.
- Door can be closed to maintain in position while adjusting hinge leaves.

HMF EXPRESS

(910) 452-1845 | Fax: (910) 452-1848 | www.HMFExpress.com

Condition 1

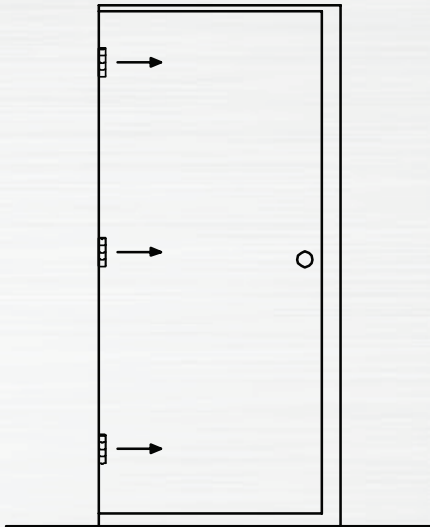

GAP TOO BIG AT LOCK EDGE

Place equal sized shims* (C) between each jamb hinge reinforcement and hinge leaf. Further adjustments can be made by placing equal sized shims* (D) behind each door hinge reinforcement.

Condition 2

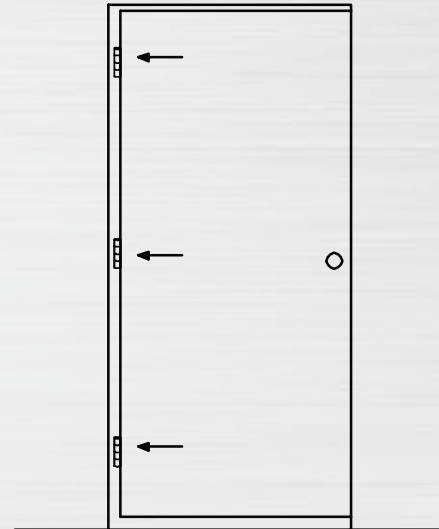

GAP TOO SMALL AT LOCK EDGE

Place equal sized shims* (A) between each jamb hinge reinforcement and hinge leaf. Further adjustments can be made by placing two equal sized shims* (B) behind each door hinge reinforcement.
NOTE: Shim* (A) when too thick can cause hinge bind when the door is closed, especially when weatherstrip is applied to the hinge rabbet.

Condition 3

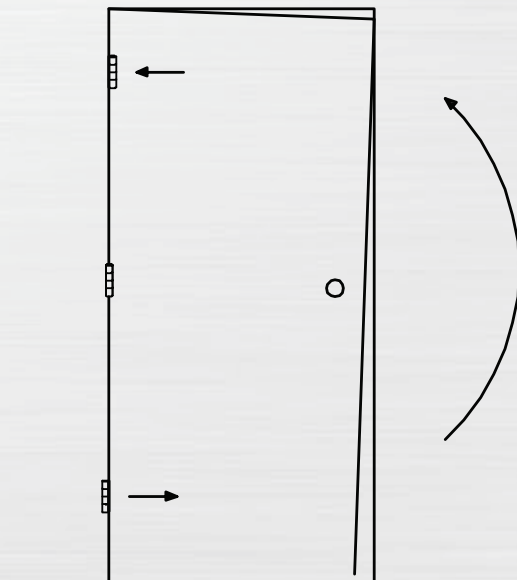

OUT OF SQUARE HINGE OR STRIKE JAMB (TOE OUT)

This condition can be improved by placing shims* (C) and/or (D) between the jamb and door hinge reinforcements respectively at the bottom hinge leaves. Further adjustment can be made by placing shim* (A) behind the top hinge which will in effect rotate the door about the middle hinge. If the strike jamb is toed out, try placing shims* (C) and (D) at the middle hinge as well. NOTE: Shim* (A) when too thick can cause hinge bind when the door is closed, especially when weatherstrip is applied to the hinge rabbet.

Condition 4

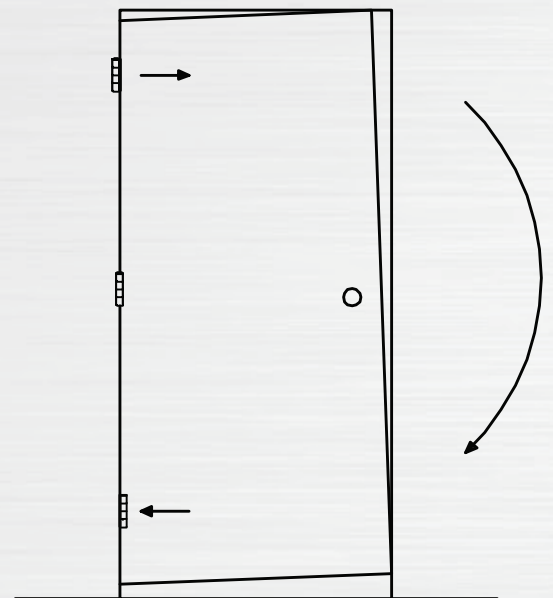

OUT OF SQUARE HINGE OR STRIKE JAMB (TOE IN)

This condition can be improved by placing shim* (A) between the bottom hinge and possibly the middle hinge as well. Further fine adjustment can be made by placing thin shims* (C) and (D) at the top hinge. NOTE: Shim* (A) when too thick can cause hinge bind when the door is closed, especially when weatherstrip is applied to the hinge rabbet.